

GRAVEL DRIVEWAY CONSTRUCTION DRAWINGS

11" x 17"

MY GRAVEL DRIVEWAY

DRAWING INDEX

- S1 TITLE SHEET
- S2 SITE PLAN EXAMPLE
- S3 SITE PLAN
- S4 CROSS SECTION
- S5 QUANTITIES EXAMPLE
- S6 QUANTITIES
- S7 DESIGN/CONSTRUCTION NOTES



PERMIT

SEAL

CLIENT

PROJECT
MY GRAVEL DRIVEWAY

SHEET TITLE
TITLE SHEET

FILE NO. **001** SHEET ID. **S1**

*THESE ARE GENERAL CONSTRUCTION DRAWINGS THAT ARE NOT SUITABLE FOR ALL SITE CONDITIONS OR LOADING CONDITIONS. THE DRAWINGS, NOTES, AND SPECIFICATIONS CONTAINED HEREIN SHOULD BE USED FOR INFORMATION ONLY. NO WARRANTY IS EXPRESSED OR IMPLIED SHOULD THESE PLANS BE USED TO CONSTRUCT A GRAVEL DRIVEWAY. YOU SHOULD NOT BUILD A GRAVEL DRIVEWAY WITHOUT FIRST CONSULTING WITH A LOCAL GEOTECHNICAL ENGINEER.

NOTES

THIS IS AN EXAMPLE SITE PLAN. SEE THE NEXT PAGE FOR A BLANK SITE PLAN PAGE THAT YOU CAN FILL OUT.

THE INSTRUCTIONS HERE ARE TO HELP YOU DETERMINE THE REQUIRED MATERIAL QUANTITIES FOR CONSTRUCTION.

1. START BY MEASURING THE OUTSIDE EDGES AROUND WHERE YOU WANT YOUR GRAVEL DRIVEWAY TO BE. MAKE SURE YOUR DRIVEWAY IS THE SAME WIDTH THROUGHOUT.

2. DRAW YOUR DRIVEWAY ON THE NEXT PAGE AND DIVIDE IT INTO RECTANGLES AND TRIANGLES, LABEL THE MEASUREMENTS ON EACH SHAPE

3. CALCULATE THE AREA OF EACH SHAPE, USING THE LENGTHS YOU DETERMINED IN STEP 2.

AREA OF RECTANGLE: LENGTH x WIDTH
AREA OF TRIANGLE: 0.5 x HEIGHT x WIDTH

SHAPE 1: 4.30 m x 3.00 m = 12.90 m²
SHAPE 2: 0.5 x 1.68 m x 4.30 m = 3.61 m²
SHAPE 3: 0.5 x 1.77 m x 4.30 m = 3.81 m²
SHAPE 4: 6.50 m x 4.30 m = 27.95 m²

4. ADD THE AREAS OF ALL THE SHAPES UP TO GET YOUR TOTAL AREA OF DRIVEWAY AND WRITE IT DOWN.

TOTAL = 12.90 + 3.61 + 3.81 + 27.95 = 48.27 m²

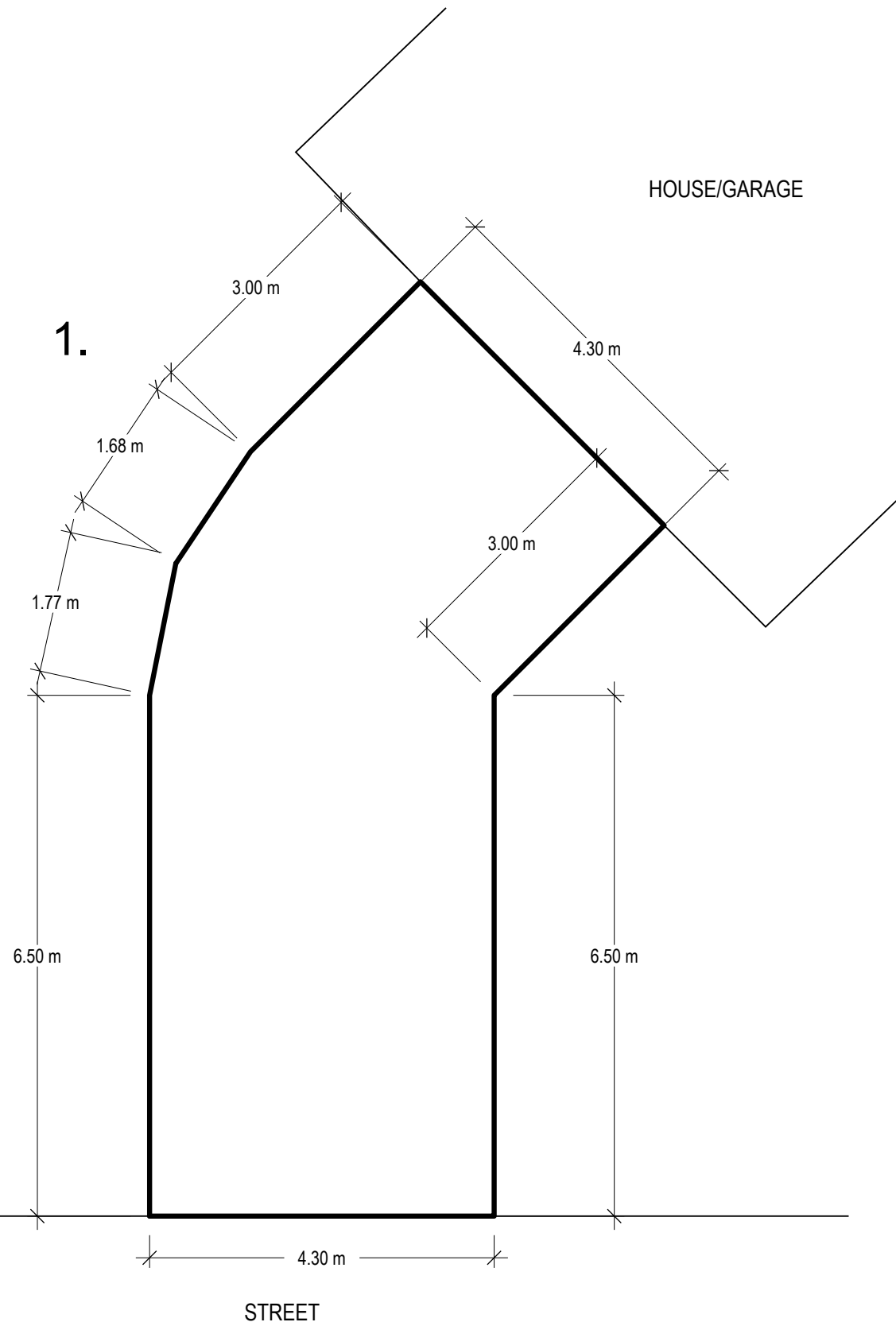

2.

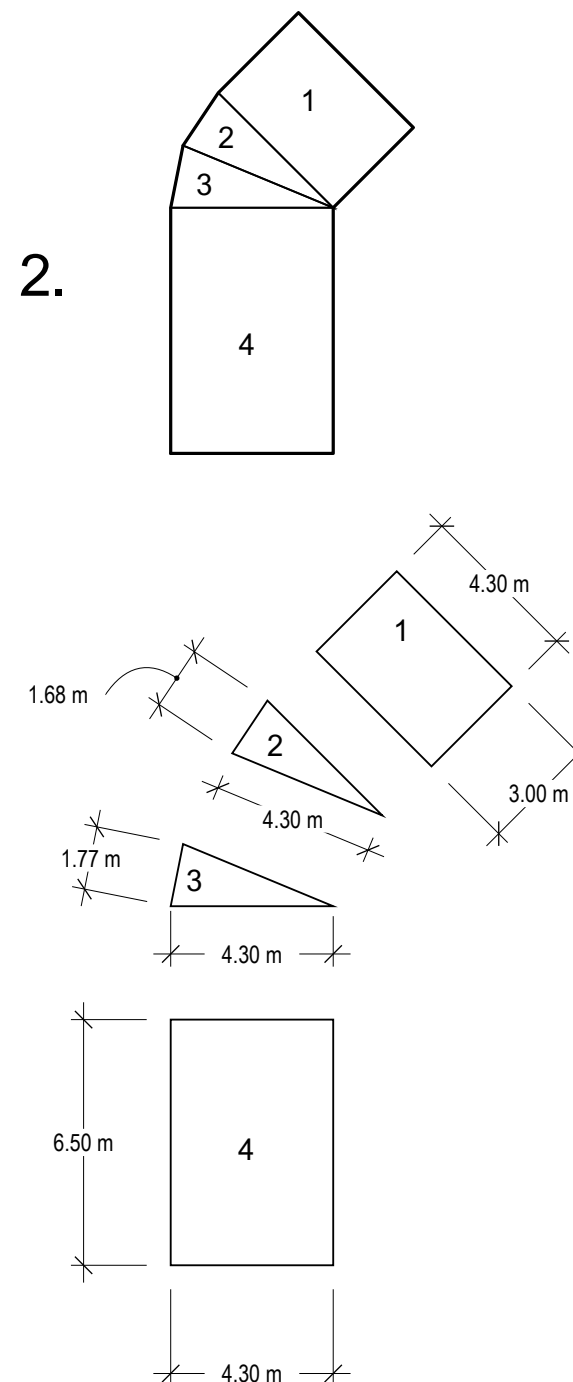

PERMIT

SEAL

CLIENT

PROJECT

MY GRAVEL DRIVEWAY

SHEET TITLE

SITE PLAN EXAMPLE

FILE NO.

001

SHEET ID.

S2

DOWNLOAD HERE

<https://factorgeo.com/free-gravel-driveaway-construction-drawings/>

SHEET SIZE 11X17

25 mm

PERMIT

SEAL

CLIENT

PROJECT

MY GRAVEL DRIVEWAY

SHEET TITLE

SITE PLAN

FILE NO.

001

SHEET ID.

S3

DOWNLOAD HERE

<https://factorgo.com/free-gravel-driveway-construction-drawings/>

SHEET SIZE 11X17

25 mm

0

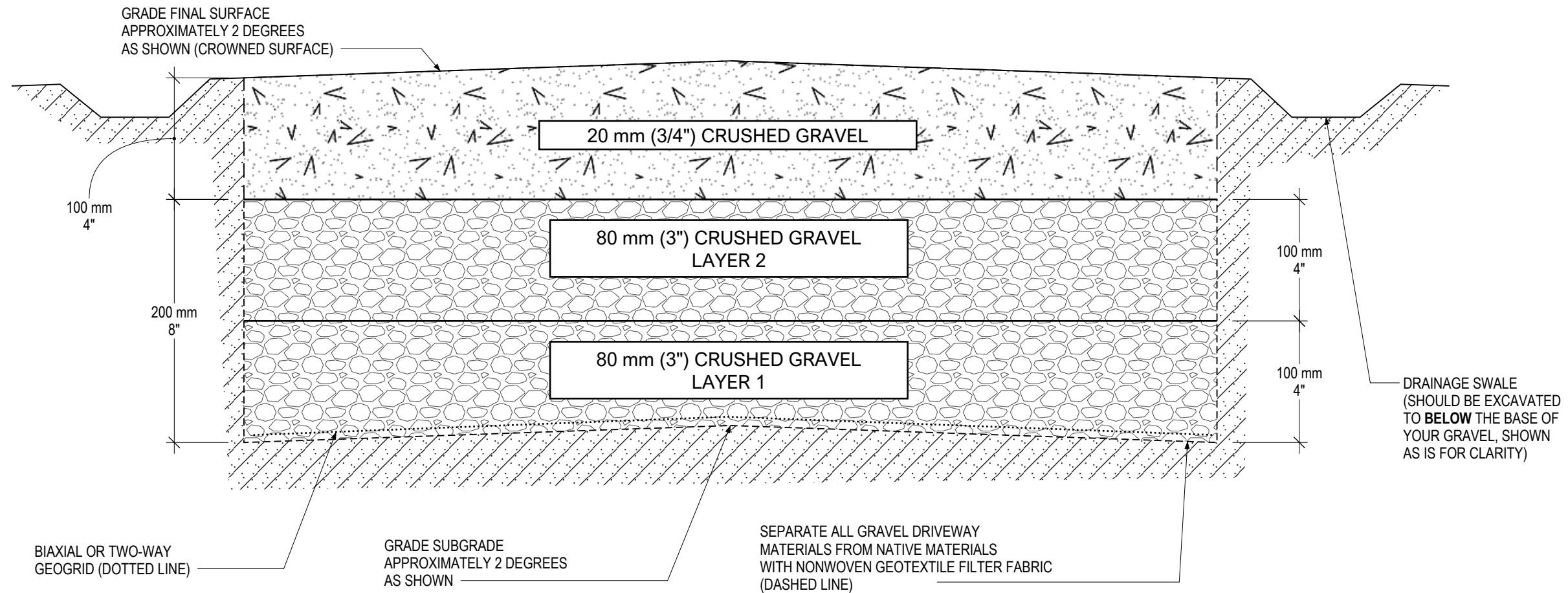

NOTES:

1. START BY EXCAVATING THE FULL DEPTH OF THE DRIVEWAY FOOTPRINT. MAKE SURE THE SOIL IS NOT SOFT, BLACK, OR WET. IF IT IS, CONTACTING A GEOTECHNICAL ENGINEER IS RECOMMENDED.

TRY DRIVING A VEHICLE OVER THE SUBGRADE BEFORE STARTING CONSTRUCTION OF THE GRAVEL DRIVEWAY. RUTTING SHOULD NOT OCCUR ON AN ACCEPTABLE SUBGRADE.

2. ONCE THE FULL DEPTH OF THE GRAVEL DRIVEWAY HAS BEEN EXCAVATED AND HAS BEEN GRADED AS SHOWN, START BY PLACING THE NON WOVEN GEOTEXTILE FILTER FABRIC.

NON WOVEN GEOTEXTILE FILTER FABRIC SHOULD BE OVERLAPPED 300 mm (1') AT ALL SEAMS AND TACKED IN PLACE.

MAKE SURE THE FILTER FABRIC GOES UP THE SIDES OF THE EXCAVATION AS WELL.

3. PLACE BIAXIAL TWO WAY GEOGRID ACROSS THE ENTIRE DRIVEWAY FOOTPRINT. OVERLAP 150 mm (6") AT SEAMS. IT IS IMPORTANT TO MAINTAIN PROPER TENSION IN THE GRID DURING INSTALLATION. TACKING THE GRID IN PLACE IS VERY HELPFUL IF YOU'RE HAVING TROUBLE.

4. PLACE LAYER 1 OF THE 80 mm (3") GRAVEL. PLACE APPROXIMATELY 110 mm (4 1/4"). COMPACT IT WITH AT LEAST 4 PASSES OF A VIBRATORY FLAT PLATE TAMPER. YOU MAY NEED TO ADD SOME WATER DURING COMPACTION. DRIVE OVER THE GRAVEL WITH A TRUCK TO SEE IF ANY RUTS FORM. IF RUTS ARE FORMING, CONTINUE COMPACTION.

5. REPEAT STEP 4, BUT FOR LAYER 2 OF THE 80 mm (3") GRAVEL.

6. PLACE THE LAYER OF 20 mm (3/4") CRUSHED GRAVEL ON TOP OF THE COMPACTED LAYER 2 AND COMPACT THE 20 mm (3/4") CRUSHED GRAVEL WITH AT LEAST 4 PASSES OF THE VIBRATORY FLAT PLATE TAMPER.

7. GRADE THE SURFACE OF THE GRAVEL DRIVEWAY SO THAT WATER IS DIRECTED TO THE EDGES OF THE DRIVEWAY.

PERMIT

SEAL

CLIENT

PROJECT

MY GRAVEL DRIVEWAY

SHEET TITLE

CROSS SECTION

FILE NO.

001

SHEET ID.

S4

80 mm (3") GRAVEL QUANTITY CALCULATION

RECALL THE TOTAL AREA CALCULATION. FROM THE EXAMPLE: **48.27 m²**

TO DETERMINE THE TOTAL VOLUME OF 80 mm (3") GRAVEL WE WILL REQUIRE, WE NEED TO MULTIPLY THE TOTAL AREA BY THE THICKNESS OF THE LAYER. MAKE SURE YOU ARE MULTIPLYING BY THE SAME UNITS! (m x m, mm x mm, foot x foot.)

BASE LAYER VOLUME = DRIVEWAY AREA x BASE LAYER THICKNESS
BASE LAYER VOLUME = 48.27 m² x 0.2 m = **9.65 m³**

AS THE GRAVEL COMPANY WILL DELIVER UNCOMPACTED MATERIAL, YOU MUST ACCOUNT FOR THE LOSS OF VOLUME FROM COMPACTING THE MATERIAL. A TYPICAL "COMPACTION FACTOR" FOR GRAVEL IS **0.88**

REQUIRED 80 mm (3") GRAVEL VOLUME = BASE LAYER VOLUME ÷ COMPACTION FACTOR
REQUIRED 80 mm (3") GRAVEL VOLUME = 9.65 m³ ÷ 0.88 = **11.0 m³**

THEREFORE, YOU REQUIRE 11.0 m³ OF GRAVEL TO BE DELIVERED.

THE COMPACTION FACTOR DEPENDS ON YOUR LOCAL GRAVEL. ASK THE GRAVEL COMPANY BY HOW MUCH YOU SHOULD INCREASE YOUR ORDER QUANTITY TO ACCOUNT FOR COMPACTION.

IT IS RECOMMENDED THAT YOU DO NOT ORDER ALL OF THE GRAVEL AT ONCE. GRAVEL TRUCKS CAN SPREAD THE GRAVEL FOR YOU, SAVING YOU A LOT OF WORK. YOU WILL ALSO BE ABLE TO ADJUST YOUR ORDER SIZE ONCE YOU SEE HOW MUCH MORE YOU NEED AFTER THE FIRST LAYER OF GRAVEL HAS BEEN COMPACTED.

START BY ORDERING HALF THE CALCULATED GRAVEL QUANTITY FOR THE BASE LAYER.

GEOTEXTILE FILTER FABRIC QUANTITY CALCULATION

RECALL THE TOTAL AREA CALCULATION. FROM THE EXAMPLE: **48.27 m²**

THIS AMOUNT DOES NOT ACCOUNT FOR THE 300 mm ON THE SIDES OF THE EXCAVATION. TO ACCOUNT FOR THIS AREA YOU'LL NEED TO MULTIPLY THE DEPTH BY THE PERIMETER LENGTH OF YOUR DRIVEWAY.

PERIMETER GEOTEXTILE AREA = PERIMETER x DEPTH

IN OUR EXAMPLE OUR PERIMETER COMES OUT TO:
4.30 m + 6.50 m + 3.00 m + 4.30 m + 3.00 m + 1.68 m + 1.77 m + 6.50 m = **31.05 m**

PERIMETER GEOTEXTILE AREA = 31.05 m x 0.3 m = **9.32 m²**
TOTAL GEOTEXTILE AREA = 48.27 m² + 9.32 m² = **57.59 m²**

REMEMBER THAT YOU'LL NEED TO OVERLAP THE GEOTEXTILE 300 mm (1') AT SEAMS, SO SUBTRACT THE OVERLAP FROM THE ROLL WIDTH, THEN DETERMINE HOW MANY ROLLS YOU NEED.

EXAMPLE: ROLL WIDTH = 3.0 m , ROLL LENGTH = 15.0 m
SO, EFFECTIVE ROLL WIDTH = 3.0 m - 0.3 m = 2.70 m
EFFECTIVE ROLL AREA = 15.0 m x 2.70 m = 40.5 m²

USUALLY YOU NEED TO BUY AN ENTIRE ROLL OF GEOTEXTILE SO YOU'LL NEED TO MULTIPLY THE WIDTH OF THE ROLL BY ITS LENGTH AND MAKE SURE THAT RESULT IS HIGHER THAN THE SUM OF THE DRIVEWAY FOOTPRINT AND PERIMETER AREA.

IN THE CASE OF OUR EXAMPLE WE WOULD NEED TO BUY 2 ROLLS OF GEOTEXTILE, AS OUR DRIVEWAY FOOTPRINT AREA OF **48.27 m²** IS LARGER THAN THE AREA OF ONE ROLL OF GEOTEXTILE.

20 mm (3/4") GRAVEL QUANTITY CALCULATION

RECALL THE TOTAL AREA CALCULATION. FROM THE EXAMPLE: **48.27 m²**

TO DETERMINE THE TOTAL VOLUME OF 20 mm (3/4") GRAVEL WE WILL REQUIRE, WE NEED TO MULTIPLY THE TOTAL AREA BY THE THICKNESS OF THE LAYER. MAKE SURE YOU ARE MULTIPLYING BY THE SAME UNITS! (m x m, mm x mm, foot x foot.)

BASE LAYER VOLUME = DRIVEWAY AREA x BASE LAYER THICKNESS
BASE LAYER VOLUME = 48.27 m² x 0.1 m = **4.83 m³**

AS THE GRAVEL COMPANY WILL DELIVER UNCOMPACTED MATERIAL, YOU MUST ACCOUNT FOR THE LOSS OF VOLUME FROM COMPACTING THE MATERIAL. A TYPICAL "COMPACTION FACTOR" FOR GRAVEL IS **0.88**

REQUIRED 20 mm (3/4") GRAVEL VOLUME = BASE LAYER VOLUME ÷ COMPACTION FACTOR
REQUIRED 20 mm (3/4") GRAVEL VOLUME = 4.83 m³ ÷ 0.88 = **5.49 m³**

THEREFORE, YOU REQUIRE 5.49 m³ OF GRAVEL TO BE DELIVERED.

THE COMPACTION FACTOR DEPENDS ON YOUR LOCAL GRAVEL. ASK THE GRAVEL COMPANY BY HOW MUCH YOU SHOULD INCREASE YOUR ORDER QUANTITY TO ACCOUNT FOR COMPACTION.

REMEMBER IT IS ALWAYS BETTER TO HAVE A LITTLE TOO MUCH GRAVEL THAN NOT ENOUGH. YOU MAY WANT TO ADD A BIT MORE VOLUME TO YOUR ORDER.

GEOGRID QUANTITY CALCULATION

RECALL THE TOTAL AREA CALCULATION. FROM THE EXAMPLE: **48.27 m²**

REMEMBER THAT YOU'LL NEED TO OVERLAP THE GEOTEXTILE 150 mm (6") AT SEAMS, SO SUBTRACT THE OVERLAP FROM THE ROLL WIDTH, THEN DETERMINE HOW MANY ROLLS YOU NEED.

EXAMPLE: ROLL WIDTH = 3.0 m , ROLL LENGTH = 15.0 m
SO, EFFECTIVE ROLL WIDTH = 3.0 m - 0.15 m = 2.85 m
EFFECTIVE ROLL AREA = 15.0 m x 2.85 m = 42.75 m²

USUALLY YOU NEED TO BUY AN ENTIRE ROLL OF GEOGRID SO YOU'LL NEED TO MULTIPLY THE WIDTH OF THE ROLL BY ITS LENGTH AND MAKE SURE THAT RESULT IS HIGHER THAN THE SUM OF THE DRIVEWAY FOOTPRINT.

IN THE CASE OF OUR EXAMPLE WE WOULD NEED TO BUY 2 ROLLS OF GEOGRID, AS OUR DRIVEWAY FOOTPRINT AREA OF **48.27 m²** IS LARGER THAN THE AREA OF ONE ROLL OF GEOGRID.

ALL CALCULATIONS DONE HERE ARE IN METRIC UNITS. THE SAME CALCULATIONS AND FORMULAS WILL WORK IN IMPERIAL (FEET/INCHES). JUST MAKE SURE YOU ARE USING THE SAME UNITS THROUGHOUT EVERY CALCULATION. USUALLY YOU WILL WANT TO CONVERT ALL OF YOUR UNITS TO INCHES, COMPLETE ALL THE CALCULATIONS, THEN CONVERT BACK TO FEET/INCHES.

SEE OUR RECOMMENDED PRODUCTS PAGE FOR THE PRODUCTS WE WOULD USE ON OUR OWN HOME
<https://factorgeo.com/free-gravel-driveway-construction-drawings/>

PERMIT	
SEAL	
CLIENT	
PROJECT MY GRAVEL DRIVEWAY	
SHEET TITLE QUANTITIES EXAMPLE	
FILE NO. 001	SHEET ID. S5

80 mm (3") GRAVEL QUANTITY CALCULATION

20 mm (3/4") GRAVEL QUANTITY CALCULATION

GEOTEXTILE FILTER FABRIC QUANTITY CALCULATION

GEOGRID QUANTITY CALCULATION

PERMIT

SEAL

CLIENT

PROJECT
MY GRAVEL DRIVEWAY

SHEET TITLE
QUANTITIES

FILE NO. **001** SHEET ID. **S6**

DESIGN NOTES

1. MATERIALS

- a) BASE GRAVEL: 80 mm (3") GRAVEL
- b) SURFACE GRAVEL: 20 mm (3/4") CRUSHED GRAVEL
- c) FILTER FABRIC: SEE OUR GRAVEL DRIVEWAY PRODUCTS PAGE
<https://factorgo.com/free-gravel-driveway-construction-drawings/>
- d) GEOGRID: SEE OUR GRAVEL DRIVEWAY PRODUCTS PAGE
<https://factorgo.com/free-gravel-driveway-construction-drawings/>

2. DRIVEWAY DESIGN DETAILS

- a) SUBGRADE: INSPECTED BY GEOTECHNICAL ENGINEER OR PROOFROLL SUBGRADE WITH CAR/TRUCK
- b) BASE LAYER:
THICKNESS: 200 mm / 8" MINIMUM - COMPACTED IN 2 LAYERS
- c) SURFACE LAYER:
THICKNESS: 100 mm / 4" MINIMUM
- d) GEOTEXTILE LOCATION: AT ALL INTERFACES OF DRIVEWAY MATERIAL AND NATIVE MATERIAL TACKED IN PLACE, OVERLAP 300 mm / 12" AT SEAMS
- e) DRAINAGE: DITCHES ON EITHER SIDE OF THE DRIVEWAY EXCAVATED TO BELOW THE BASE OF THE DRIVEWAY
WIDTH: 300 mm / 12" AT TOP, 100 mm / 4" AT BASE
DEPTH: 300 mm / 12" MINIMUM
- f) GEOGRID LOCATION: PLACE AT BASE ACROSS ENTIRE DRIVEWAY FOOTPRINT TACKED IN PLACE, OVERLAP 150 mm / 6" AT SEAMS

3. INSPECTION/MATERIAL TESTING REQUIREMENTS

- a) SUBGRADE INSPECTED BY GEOTECHNICAL ENGINEER OR PROOFROLLED WITH TRUCK OR CAR
- b) EACH LAYER OF GRAVEL TO BE COMPACTED WITH A FLAT PLATE VIBRATORY TAMPER UNTIL HARD MINIMUM OF 4 PASSES WITH THE FLATE PLATE TAMPER
ADD WATER AS NECESSARY

CONSTRUCTION NOTES

1. SUBGRADE PREPARATION

- a) EXCAVATE DRIVEWAY FOOTPRINT TO THE FULL DEPTH OF YOUR CROSS SECTION. A THICKER CROSS SECTION WILL PERFORM BETTER. THE CROSS SECTION IN THESE PLANS (300 mm / 12") IS THE MINIMUM RECOMMENDED THICKNESS.
- b) CLEAR THE AREA UNDER THE PROPOSED DRIVEWAY OF ALL VEGETATION, TOPSOIL, BRUSH, SOD, CONSTRUCTION DEBRIS OR OTHER ORGANIC MATERIAL
- c) HAVE THE SUBGRADE INSPECTED BY A GEOTECHNICAL ENGINEER OR PROOFROLL WITH A TRUCK/CAR
- d) GRADE SURFACE OF SUBGRADE 2 DEGREES TO EITHER SIDE OF THE DRIVEWAY TO PREVENT WATER FROM PONDING WITHIN GRAVEL

2. GEOTEXTILE FILTER FABRIC PLACEMENT

- a) GEOTEXTILE FILTER FABRIC IS TO BE PLACED AT ALL INTERFACES BETWEEN DRIVEWAY MATERIALS AND NATIVE MATERIALS TO PREVENT THE MIGRATION OF FINE SOIL PARTICLES
- b) TACK GEOTEXTILE IN PLACE WITH SOIL STAPLES
- c) A MINIMUM OVERLAP OF 300 mm IS REQUIRED BETWEEN ALL PIECES OF FILTER FABRIC

3. GEOGRID PLACEMENT

- a) GEOGRID TO BE PLACED ACROSS ENTIRE DRIVEWAY FOOTPRINT
- b) GEOGRID IS TO BE TENSIONED UNTIL TAUT, FREE OF WRINKLES, AND LAYING FLAT
- c) STAPLES OR FILL MAY BE UTILIZED TO MAINTAIN GEOGRID TENSION, AS NECESSARY
- d) A MINIMUM OVERLAP OF 150 mm IS REQUIRED AT ALL GEOGRID SEAMS
- e) SPEED AND TURNING OF TRACKED EQUIPMENT SHOULD BE KEPT TO A MINIMUM WHEN OPERATING OVER GEOGRID. SUDDEN BRAKING, AND SHARP TURNING ARE NOT PERMITTED OVER GEOGRID

4. FILL PLACEMENT

- a) PLACE FILL IN MAXIMUM 100 mm / 4" LIFTS
- b) COMPACT UNTIL HARD WITH A FLATE PLATE VIBRATORY TAMPER WITH A MINIMUM OF 4 PASSES OVER EACH AREA
- c) ADD WATER AS NECESSARY. A LITTLE WATER GOES A LONG WAY WHEN DEALING WITH GRAVEL.
- d) LIGHTLY RAKE SURFACE OF LIFTS BEFORE ADDING ANOTHER LIFT

5. FINAL GRADING AND LANDSCAPING

- a) GRADE SURFACE OF TOP LAYER OF GRAVEL 2 DEGREES TO EACH SIDE OF THE DRIVEWAY TO DIRECT RAINWATER AWAY FROM THE GRAVEL
- b) DRIVEWAY EDGING WITH BRICKS OR OTHER MATERIAL IS RECOMMENDED TO BETTER CONTAIN GRAVEL.

6. LIMITATIONS

- a) THE DRAWINGS AND INSTRUCTIONS CONTAINED WITHIN THIS DOCUMENT ARE NOT A SUBSTITUTE FOR ENGINEERING ADVICE OR RECOMMENDATIONS.
- b) THIS DOCUMENT SHOULD NOT BE USED FOR THE CONSTRUCTION OF ANY ROAD OR DRIVEWAY WITHOUT CONSULTATION FROM A QUALIFIED, LOCAL GEOTECHNICAL ENGINEER

PERMIT

SEAL

CLIENT

PROJECT

MY GRAVEL DRIVEWAY

SHEET TITLE

DESIGN/CONSTRUCTION NOTES

FILE NO.

001

SHEET ID.

S7

DOWNLOAD HERE

<https://factorgo.com/free-gravel-driveway-construction-drawings/>

SHEET SIZE 11X17

25 mm

0